



# Making Good Spaces into Great Places: Nevin & Eddyside Parks

Final Report: Spring 2014  
Lafayette College  
Technology Clinic

# Table of Contents



- What is Technology Clinic? - page 3
- The Team – page 5
- Our Goals – page 6
- Park Visions – page 7
- Methodology - page 20
- Actions to Reach the Vision - page 30
  - Park Programming - page 32
  - Crossings between Nevin and Eddyside - page 40
- Parking - page 46
- Handicap Access - page 47
- Event Communication - page 48
- Place Changes in Nevin Park - page 53
- Place Changes in Eddyside- page 59
- Making Choices - page 65
- Conclusion - page 74
- Acknowledgements- page 75
- Appendices - page 76

# What is Technology Clinic?



The Technology Clinic is a program that engages a small group of students, nominated by professors and facilitated by Lafayette College faculty. Each team is interdisciplinary, with members selected from sciences, social sciences, engineering and humanities. Since the Technology Clinic's founding in 1986, the course has offered its participants rewarding experiences through projects that emphasize problem-solving and consulting skills.

# What is Technology Clinic?



Each Technology Clinic team tackles a project that spans two semesters. Nearly 75 projects have been completed since 1986. Past projects include:

- Creating a waterfront improvement plan for Easton and Phillipsburg,
- Designing bird flu immunization procedures for the Allentown Health Bureau,
- Developing programs for improving nutrition in the West Ward of Easton,
- Designing a debris harvester that is now a world-wide application.

# The Team

Erin Townley ('14): Neuroscience major and Spanish minor

Charles Vincent ('14): Mathematics major

Caitie Hope ('15): English and Women's & Gender Studies double major

Maura Schluskel ('15): Neuroscience major with an Economics minor

Brian Dierze ('16): Government & Law and Spanish double major with a minor in Economics

Rebeka Ramangamihanta ('16): International Affairs and Economics double major

Dan Bauer: Faculty facilitator since 1986, PhD in Anthropology, interest in engineering and technology

# Our Goals



- Goals for the project are to present viable possibilities to make two neighborhood parks great, including steps aimed at:
  - Improved aesthetics
  - Greater cohesiveness between the parks
  - Enhanced interaction among neighbors
  - The parks becoming destinations
  - Continuing park improvement

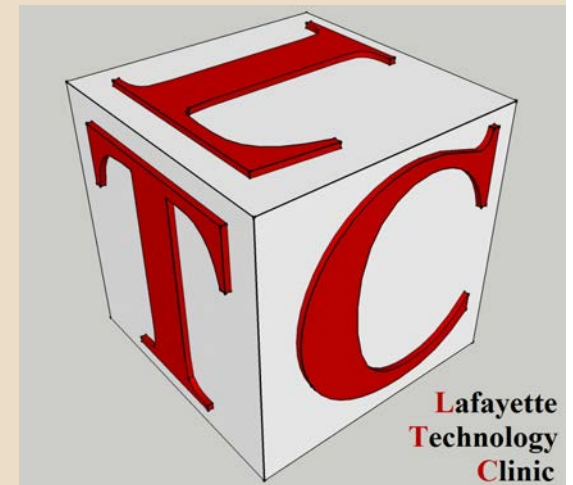

# Park Visions



As the sun approached its zenith, the crowds of people walking up the riverside trail swelled in number. The sun was glinting off of the pristine waterway to my right, the ripples of water moving like dancers around the surface. I was confused to find myself surrounded by so many people all of a sudden, but it seemed as if the masses were drawn to the faint sound of children laughing in the distance. The source of that laughter? Eddyside Park. As I rounded the bend and Eddyside park came into view, my wandering eyes were first met by a large green expanse sparsely populated with frolicking park goers.



The luscious grass tickled my hands as I sat down to observe. People weaved around me, laughing and talking without a care in the world. Over on the side, I saw some people throwing what seems to be rubber disks onto some sort of board.



Intrigued, I approached and asked them what they were doing. The four adults then proceeded to tell me about the game of Quoits, a favorite local pastime. They directed my gaze to the actual enclosure that took up the majority of the space, where it seems you could check out the quoits disks.

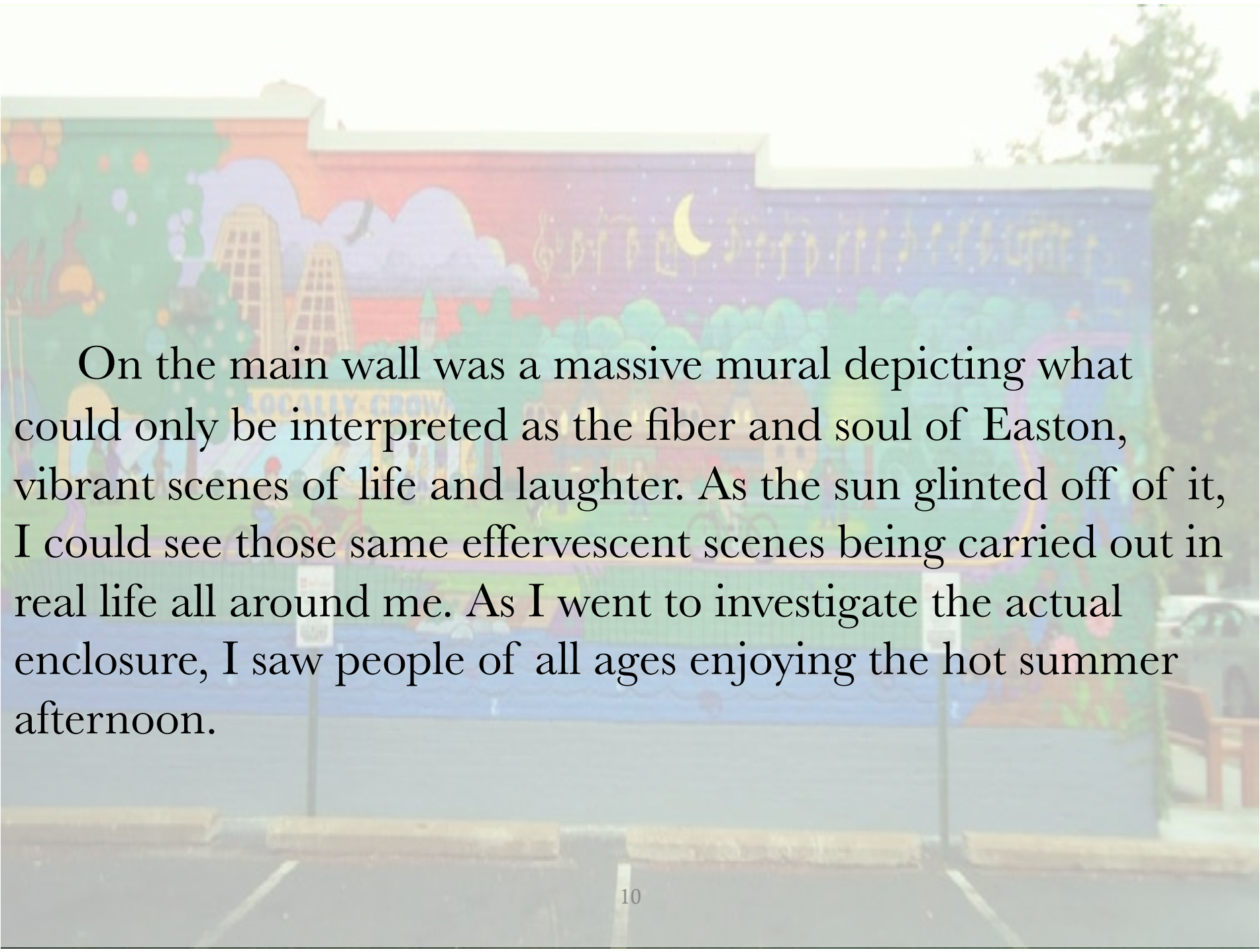

On the main wall was a massive mural depicting what could only be interpreted as the fiber and soul of Easton, vibrant scenes of life and laughter. As the sun glinted off of it, I could see those same effervescent scenes being carried out in real life all around me. As I went to investigate the actual enclosure, I saw people of all ages enjoying the hot summer afternoon.

Teenagers were continuously gathering and dispersing like the ebb and flow of the tides, as if the park was an unofficial meeting place. On either side of me were glimmering pools filled with energetic and glistening children frolicking in the relative comfort of the cool water.

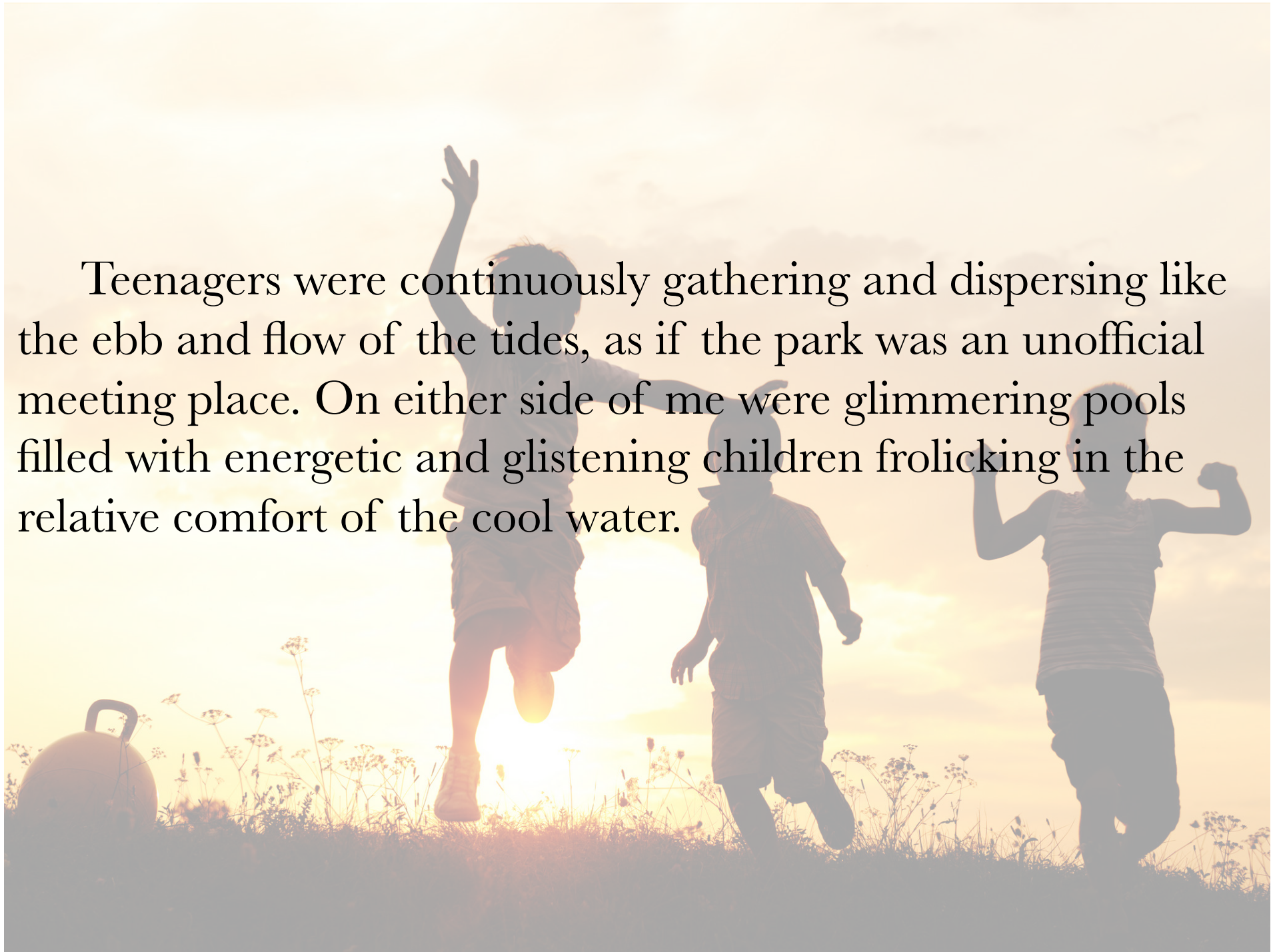

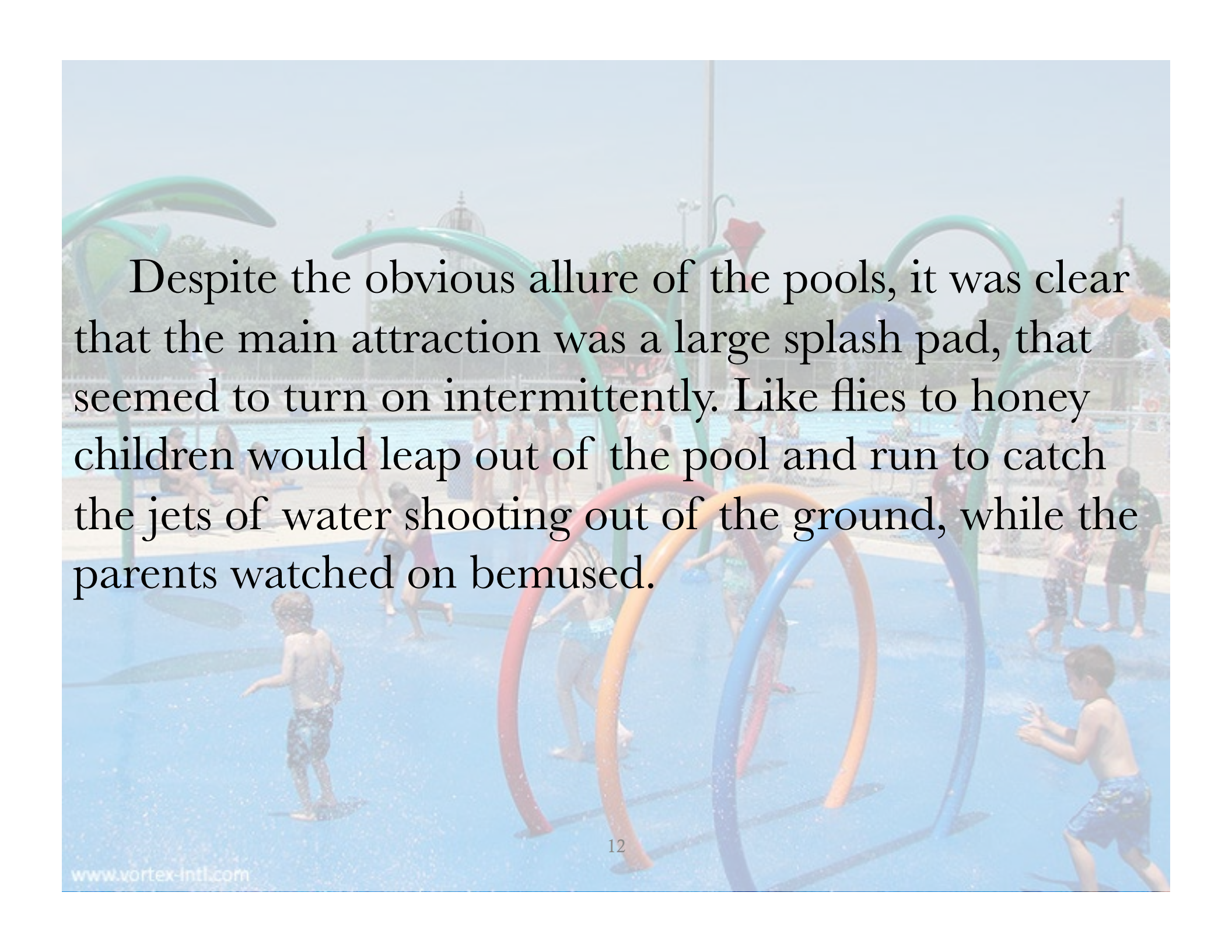

Despite the obvious allure of the pools, it was clear that the main attraction was a large splash pad, that seemed to turn on intermittently. Like flies to honey children would leap out of the pool and run to catch the jets of water shooting out of the ground, while the parents watched on bemused.

Despite the relative chaos, those adults and parents were splayed out reading books, conversing, and of course tossing out the occasional stern reminder to play nice and come back for more sunscreen.

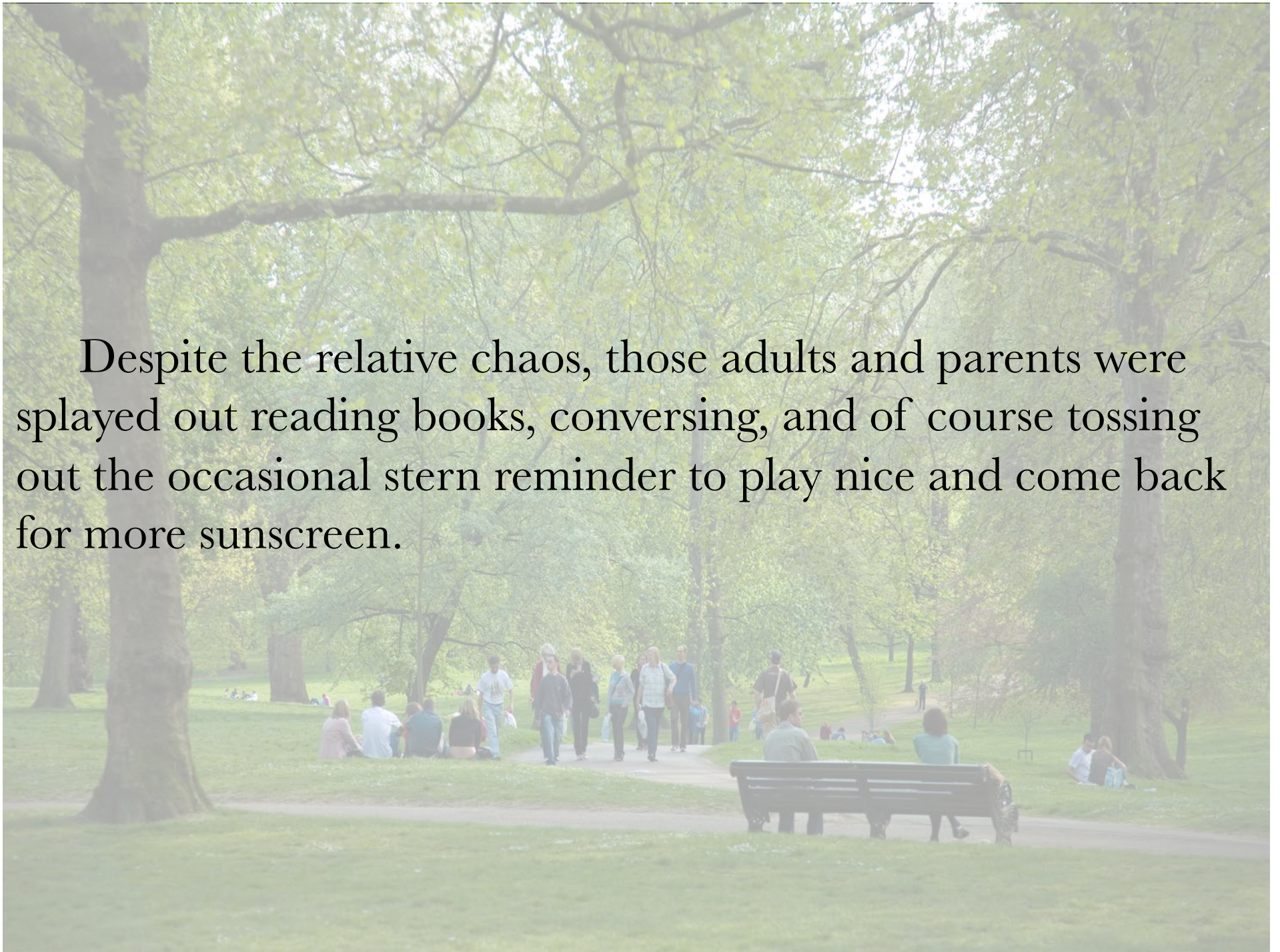

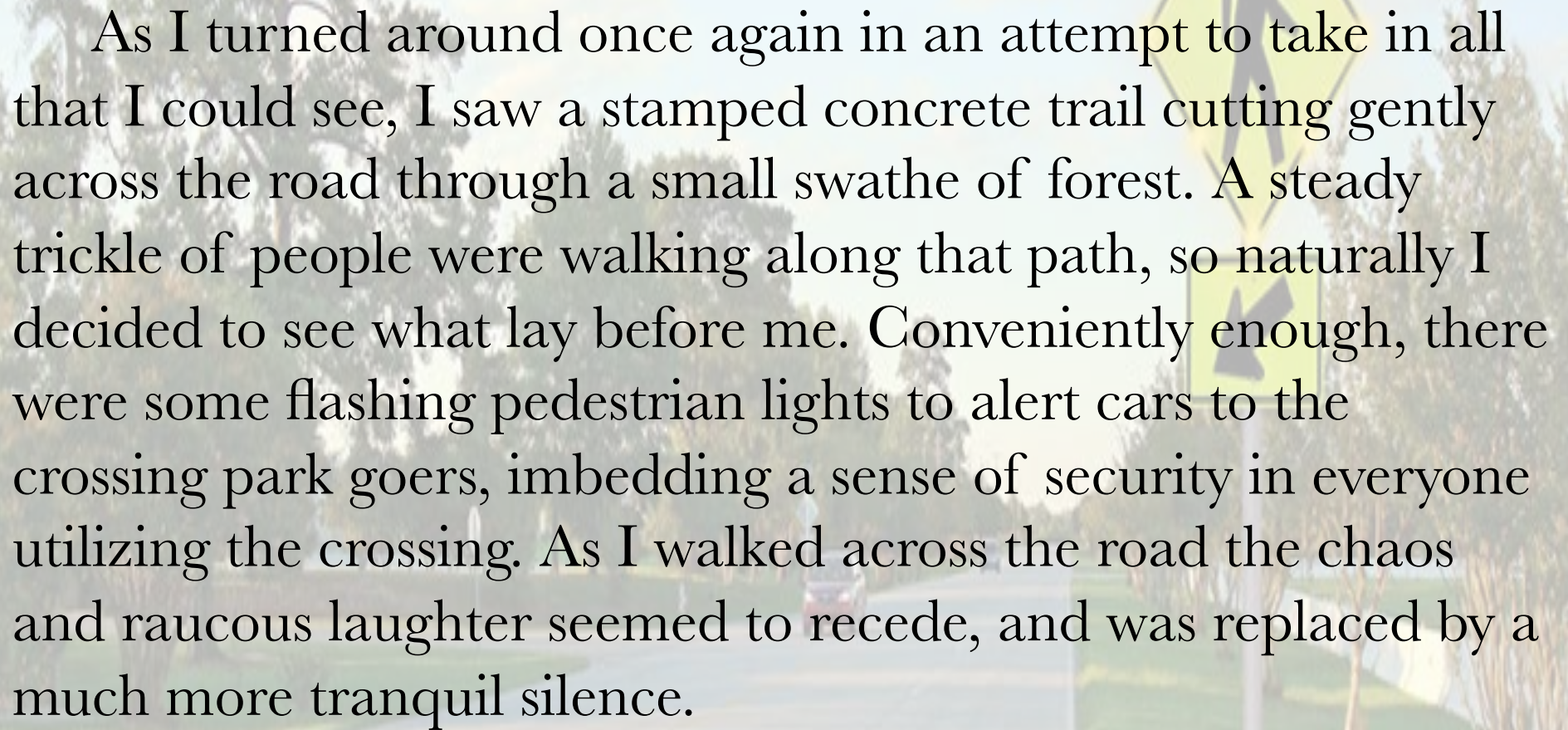

As I turned around once again in an attempt to take in all that I could see, I saw a stamped concrete trail cutting gently across the road through a small swathe of forest. A steady trickle of people were walking along that path, so naturally I decided to see what lay before me. Conveniently enough, there were some flashing pedestrian lights to alert cars to the crossing park goers, imbedding a sense of security in everyone utilizing the crossing. As I walked across the road the chaos and raucous laughter seemed to recede, and was replaced by a much more tranquil silence.

The dull thwack of tennis balls started to greet my ears as a pair of tennis courts came into sight. I continued walking up the hill and could see a sign in the distance welcoming me to what I learned was Nevin Park.

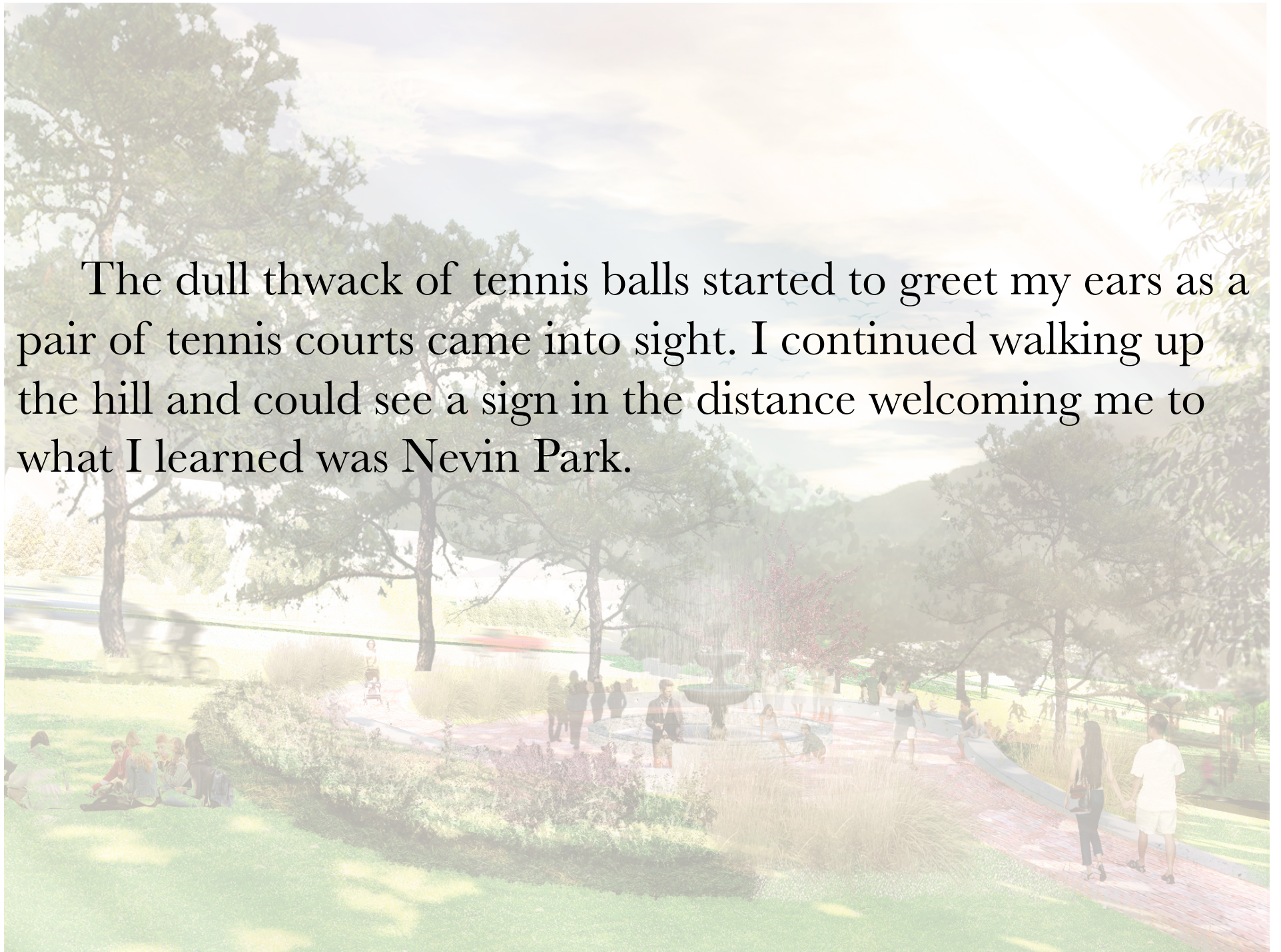

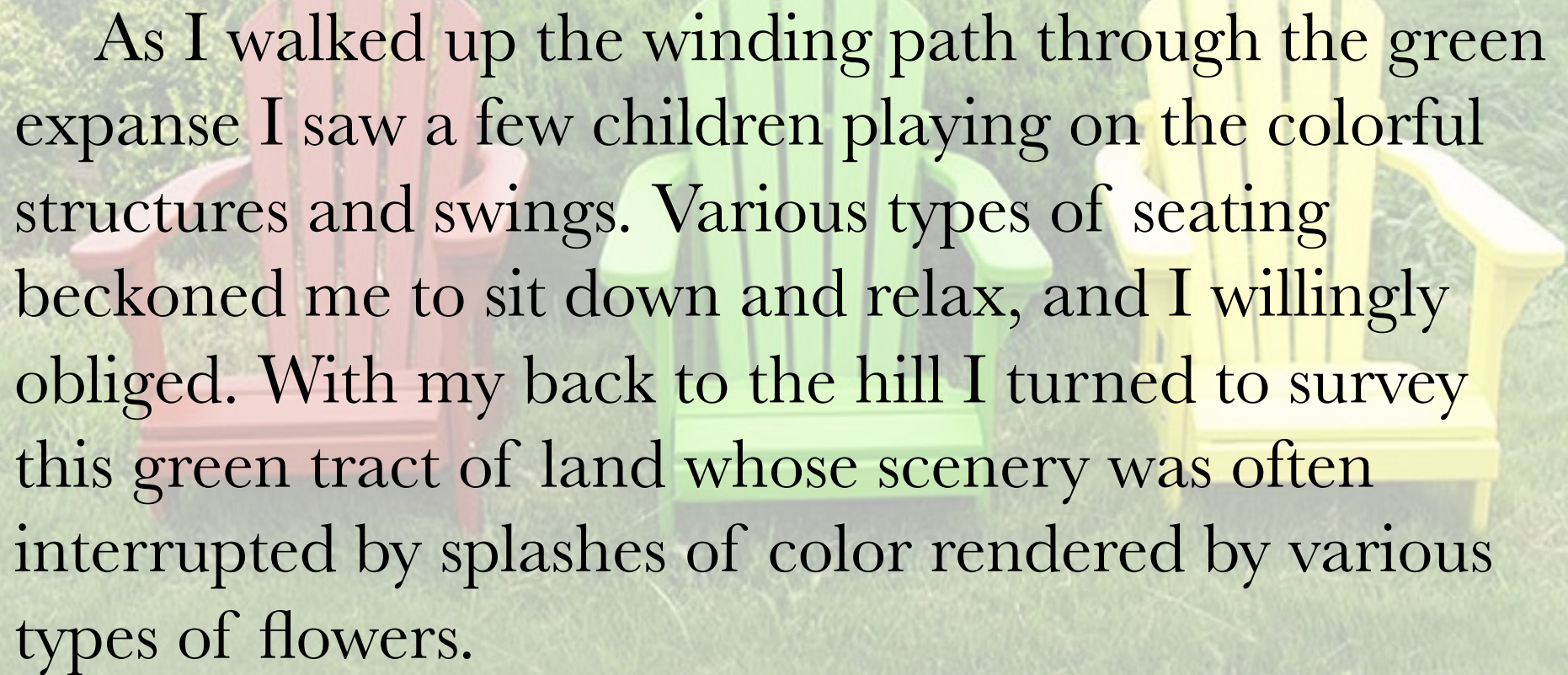
The background of the page is a photograph of three Adirondack chairs sitting on a grassy hill. The chairs are colored red, green, and yellow from left to right. The hill is covered in green grass and some small white flowers. In the background, there are dense green bushes and trees. The text is overlaid on this image.

As I walked up the winding path through the green expanse I saw a few children playing on the colorful structures and swings. Various types of seating beckoned me to sit down and relax, and I willingly obliged. With my back to the hill I turned to survey this green tract of land whose scenery was often interrupted by splashes of color rendered by various types of flowers.



Farther down below the tennis courts I noticed the flitting movements of dogs playing in a subtly enclosed area, while their owners struck up casual conversations with each other.

As I got up to continue my stroll onwards, I heard the splashing of water; I had now come to what was clearly the crowning patriarch of Nevin Park; a softly gurgling fountain. A young couple sat on the side of it tracing their hands along the surface of the water, occasionally stealing a smile and a kiss.

Next to them was a pair of elderly citizens playing chess on the built in chess tables near the fountain, being cooled by the occasional splashes of water emanating from it.

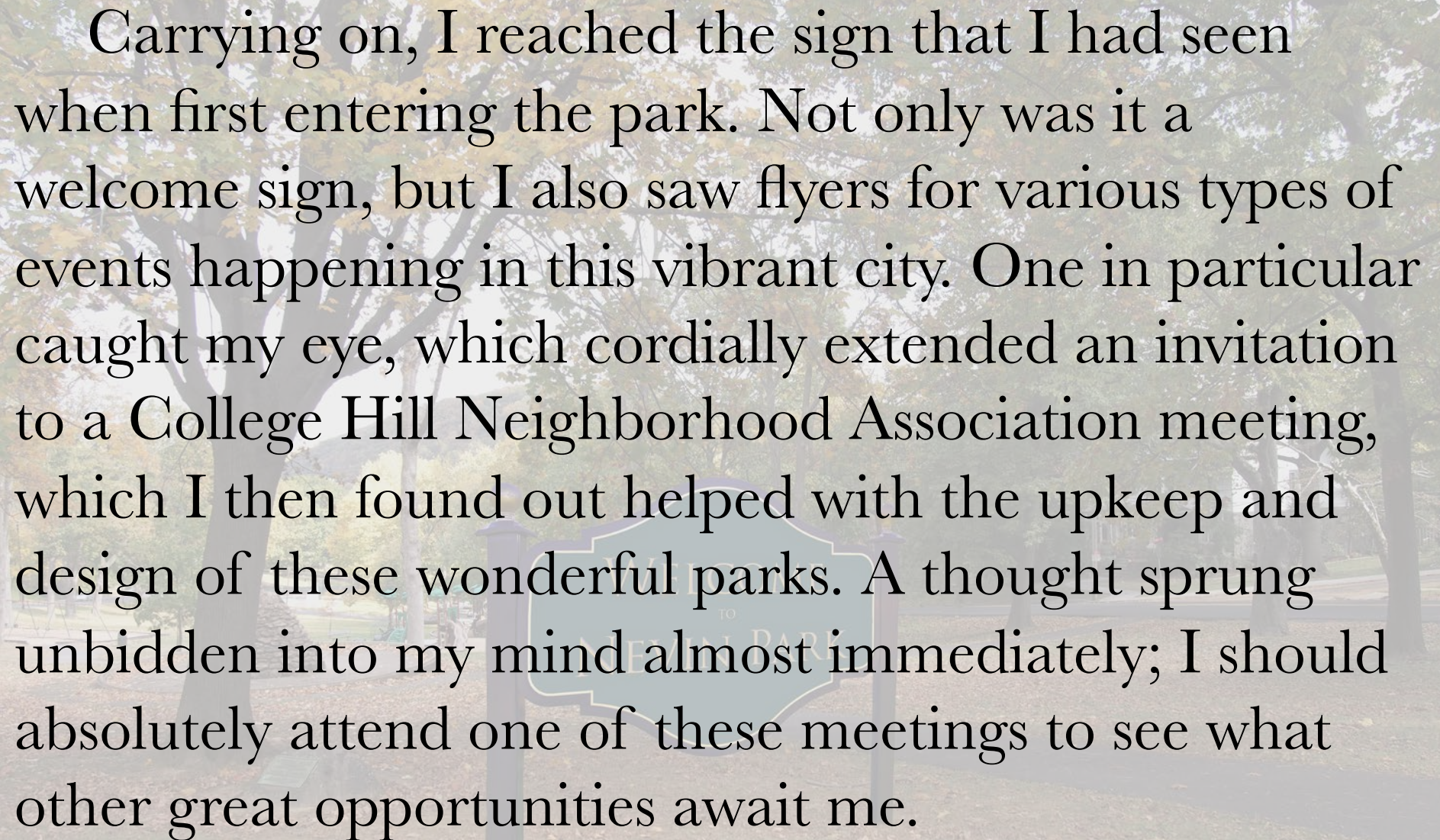

The background of the slide is a photograph of a park. In the center, there is a large, dark-colored sign with white text that reads "WELCOME TO COLLEGE HILL NEIGHBORHOOD ASSOCIATION". The sign is partially obscured by the text overlay. The park has many trees with green and yellow leaves, suggesting an autumn setting. The ground is covered with fallen leaves and grass.

Carrying on, I reached the sign that I had seen when first entering the park. Not only was it a welcome sign, but I also saw flyers for various types of events happening in this vibrant city. One in particular caught my eye, which cordially extended an invitation to a College Hill Neighborhood Association meeting, which I then found out helped with the upkeep and design of these wonderful parks. A thought sprung unbidden into my mind almost immediately; I should absolutely attend one of these meetings to see what other great opportunities await me.

# Methodology



- PPS
  - A multinational corporation called “Projects for Public Spaces” which turns spaces into places
  - Two members of the team took a 3 day course from this organization
- Wise Decider Software
- Place game
  - A widely used tool used to evaluate positive and negative aspects of a place
- Favorite park experiences

# Place Game Questionnaire

The Place Game is a tool for evaluating a public place's strengths and weaknesses at first glance:

- Grading its sociability
- Uses and activities
- Access and linkage
- Comfort and image

SITE #: \_\_\_\_\_ Date: \_\_\_\_\_

## Rate the Place:

COMFORT & IMAGE	POOR		GOOD	
Overall attractiveness	1	2	3	4
Feeling of safety	1	2	3	4
Cleanliness/Quality of Maintenance	1	2	3	4
Comfort of places to sit	1	2	3	4

Comments/Notes:

ACCESS & LINKAGES	POOR		GOOD	
Visibility from a distance	1	2	3	4
Ease in walking to the place	1	2	3	4
Transit access	1	2	3	4
Clarity of information/signage	1	2	3	4

Comments/Notes:

USES & ACTIVITIES	POOR		GOOD	
Mix of stores/services	1	2	3	4
Frequency of community events/activities	1	2	3	4
Overall busy-ness of area	1	2	3	4
Economic vitality	1	2	3	4

Comments/Notes:

SOCIABILITY	POOR		GOOD	
Number of people in groups	1	2	3	4
Evidence of volunteerism	1	2	3	4
Sense of pride and ownership	1	2	3	4
Presence of children and seniors	1	2	3	4

Comments/Notes:

## Identify Opportunities

1. What do you like best about this place?
2. What uses and activities would bring you to this place alone or with your family, friends, co-workers? Please list.
3. What existing programs, events and features you know of could be attracted to this place? Please be as specific as possible.
4. Ask someone who is in the "place" what they like about it and what they would do to improve it. Their answer:
5. What local partnerships or local talent can you identify that could help implement some of your proposed improvements? Please be as specific as possible.

PLACE GAME

# Gathering Information



Observations of the park at different times and in different seasons

- Engaged the community members found utilizing the park as well as approximately 100 community members
- Photographs of the park were taken to ensure accuracy of details
- Conversated with community members who have a daily role in maintaining the park
- Gathered information from the Mid-Year Presentation

# Acting on Information



- Used solutions from other parks and then applied them to Nevin and Eddyside Parks.
- Ensured that the discussion took into account the multiple variables and options for each solution.
  - Evaluated the Pros and Cons of each solution.
    - SWOT (Strengths, Weaknesses, Opportunities, and Threats)
    - Wise Decider Software

# PPS: Lighter, Quicker, Cheaper



“Lighter, Quicker, Cheaper” (LQC)

- Describes a local development strategy that has produced some of the world’s most successful public spaces —one that is lower risk and lower cost, capitalizing on the creative energy of the community to efficiently generate new uses and revenue for places in transition.

- Eric Reynolds at Urban Space Management

- Community-led based approach
- Light, Quick and Inexpensive
- Experiment (Change/Replace infrastructures/activities)
- Flexible for multiple uses





## LQC&PPS at Harvard Plaza

- Flexible space lends itself to use

- “If you build it, they will come”

Images: courtesy of PPS



# Place/Community Driven Approach

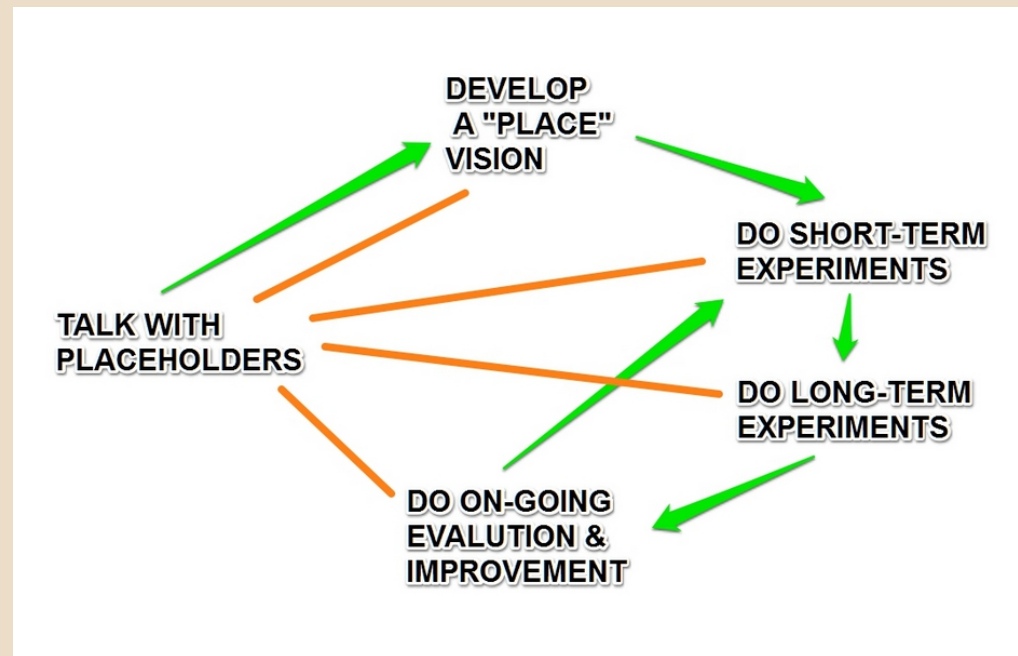

First, we spoke with stakeholders to understand their current impressions of the parks and their future hopes for Nevin and Eddyside. We used this information to create a “place” vision that reflected their input. As a continuation, short and long-term experiments as well as on-going evaluations should be performed by the CHNA and other interested parties to make the parks even better places. *This is never-ending process.*

# The Power of Ten

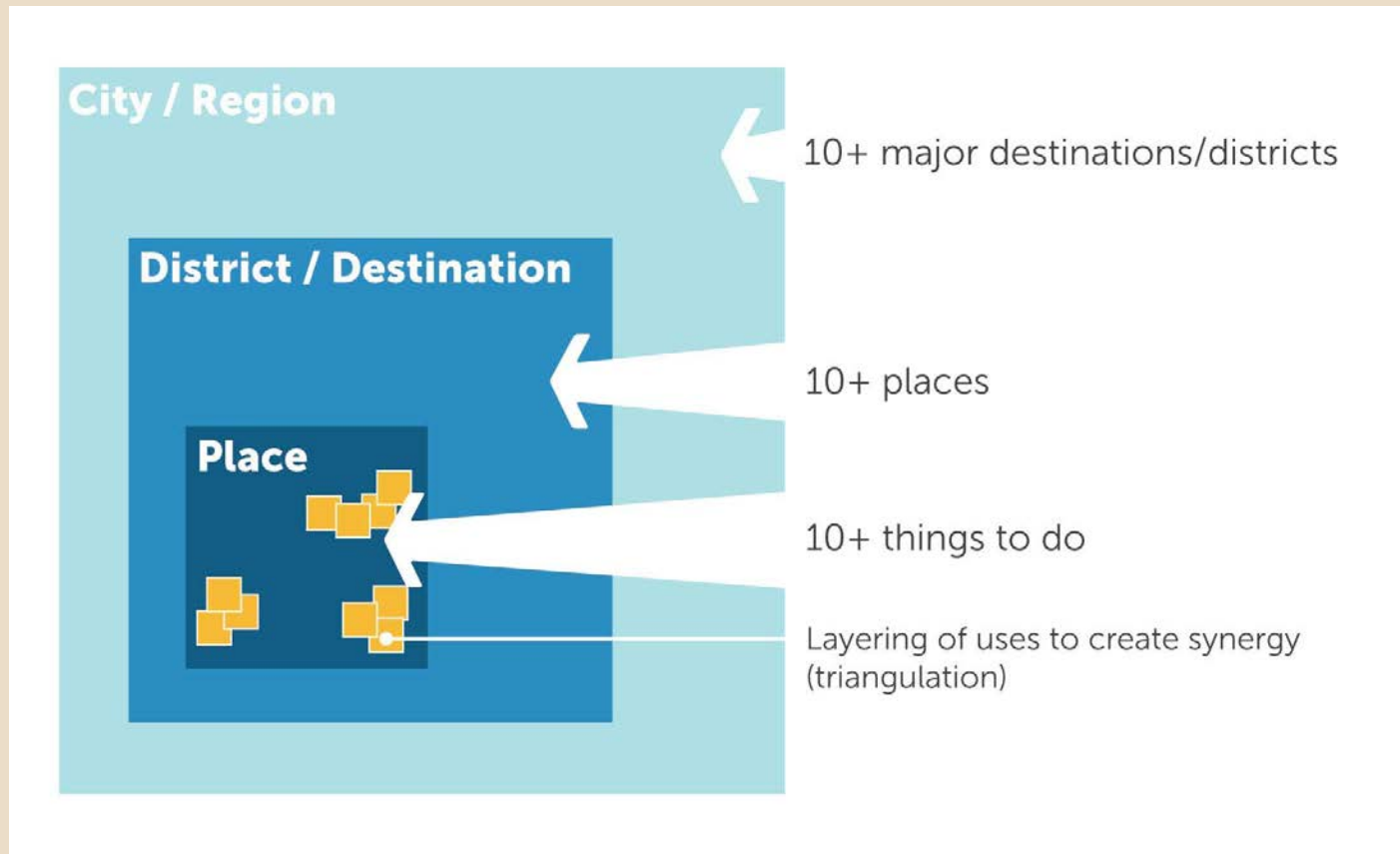

The theory behind the Power of Ten is to create a destination by providing at least ten things to do in every space.

# The Power of 10 in Practice



- Easton would have 10 major destinations or districts (The West Ward, College Hill, Downtown).
- Destinations or districts would have 10 places in each of them (using College Hill, examples would be: Lafayette College, the Easton Waterfront, Nevin Park, and Eddyside Park).
- Each place would have 10 things to do (using Nevin Park, examples would be: playing on the structure, playing tennis, reading a book etc).

# Current “Places”



- Nevin Park
  - Rock Statue
  - Two playgrounds and one swing-set
  - Tennis court
  - Basketball court
- Eddyside Park
  - Two swimming pools
  - Food stand
  - River overlook
  - Sand volleyball court
  - Pavilion and grill area

# Actions to Reach the Vision



- The following actions will be discussed in greater detail later in the report:
  - Paint a mural at Eddyside
  - Create a river boardwalk
  - Provide flexible seating options
  - Foster community engagement through programming
  - Provide a restroom location at Nevin
  - Improve parking during events

# Actions to Reach the Vision



- Improve the sense of park safety
- Build a natural amphitheater, install a gazebo, and create a dog park
- Create wheelchair-friendly paths and resting areas
- Connect Nevin and Eddyside with a crossing path at 611
- Improve signage at Wawa and parks
- Make use of grid pavers to enhance draining in Nevin

# Park Programming



- Make use of current park features
- Utilize suggested park additions
  - Not clutter the parks, but serve a purpose
- Enhance existing events



# Winter Programming

- Meet Santa
- Tree-lighting ceremony
- Caroling



<http://blog.outdoorlights.com/tag/tree-lighting/>



[http://www.christmas-light-source.com/How-many-Christmas-lights-on-my-tree-calculator\\_c\\_213.html](http://www.christmas-light-source.com/How-many-Christmas-lights-on-my-tree-calculator_c_213.html)



<http://evgrieve.com/2012/12/at-tompkins-square-park-holiday-tree.html>

# Spring Programming



- Meet the Easter Bunny
- Community-wide Easter Egg Hunt
- Make Nevin Park a destination



<http://www.kew.org/visit-kew-gardens/whats-on/past-festivals-events/easter-2012/easter-weekend/>

# Spring Programming



- Flower festivals
  - Forsythia, daffodils, lilacs, etc
- Family bulb planting
- Doggie Meet & Greet

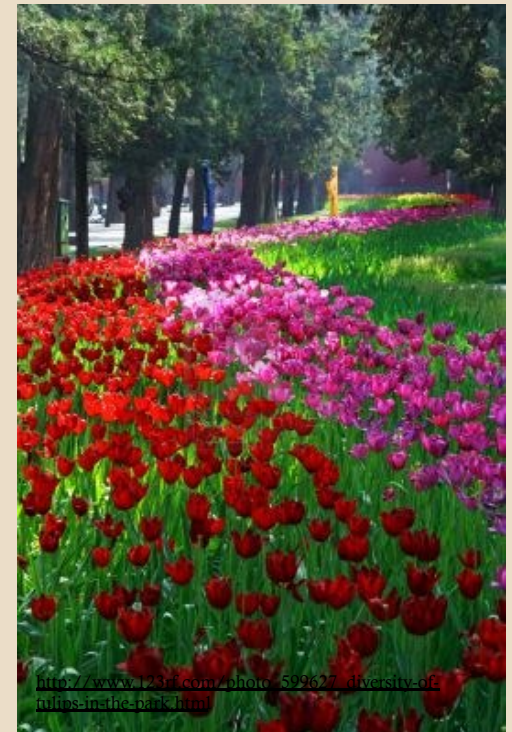

# Summer Programming



- Car shows: perhaps a dual-park show - classic European in Nevin and classic American at Eddyside
- Weekly or bi-weekly movie events
- 5k/10k or color run for a cause
- Yoga, Tai Chi, etc.
- Organized one-day tennis/ basketball tournaments



[http://www.epng.ca/?attachment\\_id=118](http://www.epng.ca/?attachment_id=118)



<https://www.visiterandforks.com/event-calendar/movie-in-the-park/06-12-2013>

# Summer Programming



- Community BBQ
- Slip-n-slide
- Book Swap
- Doggie Meet & Greet
- Eddyside: line dancing and bingo



<http://daytonymca.blogspot.com/2010/05/slip-n-slide.html>



# Fall Programming



- Fall Fest
  - Face painting, pumpkin painting, bobbing for apples, BBQ, various game stations.
  - Attract all age groups
- Family bulb planting
- Doggie Meet & Greet
- 5k/10k
  - Turkey Trot
- Local Pub/Wine Tasting/Cheese/Local band event
  - Appeal to College Hill adults



<http://blogmyflorist.com/washington-dc-area-events/outdoors/fall-scenic-drives-near-dc/>

# Business Involvement in the Park



- Food vendors at the park for special events
- Involvement of local restaurants for events
- Partnership with schools
  - Lafayette College
  - March School
- Display community members' artwork such as paintings, photography, and other crafts
- Musical and theatrical performances in amphitheater

# Crossing Between Nevin and Eddyside



- Through our observations, the two most important considerations when developing a connection between Nevin and Eddyside Parks are:
  - Accessibility
  - Safety
- The following are the ideas developed for the crossing between the parks.



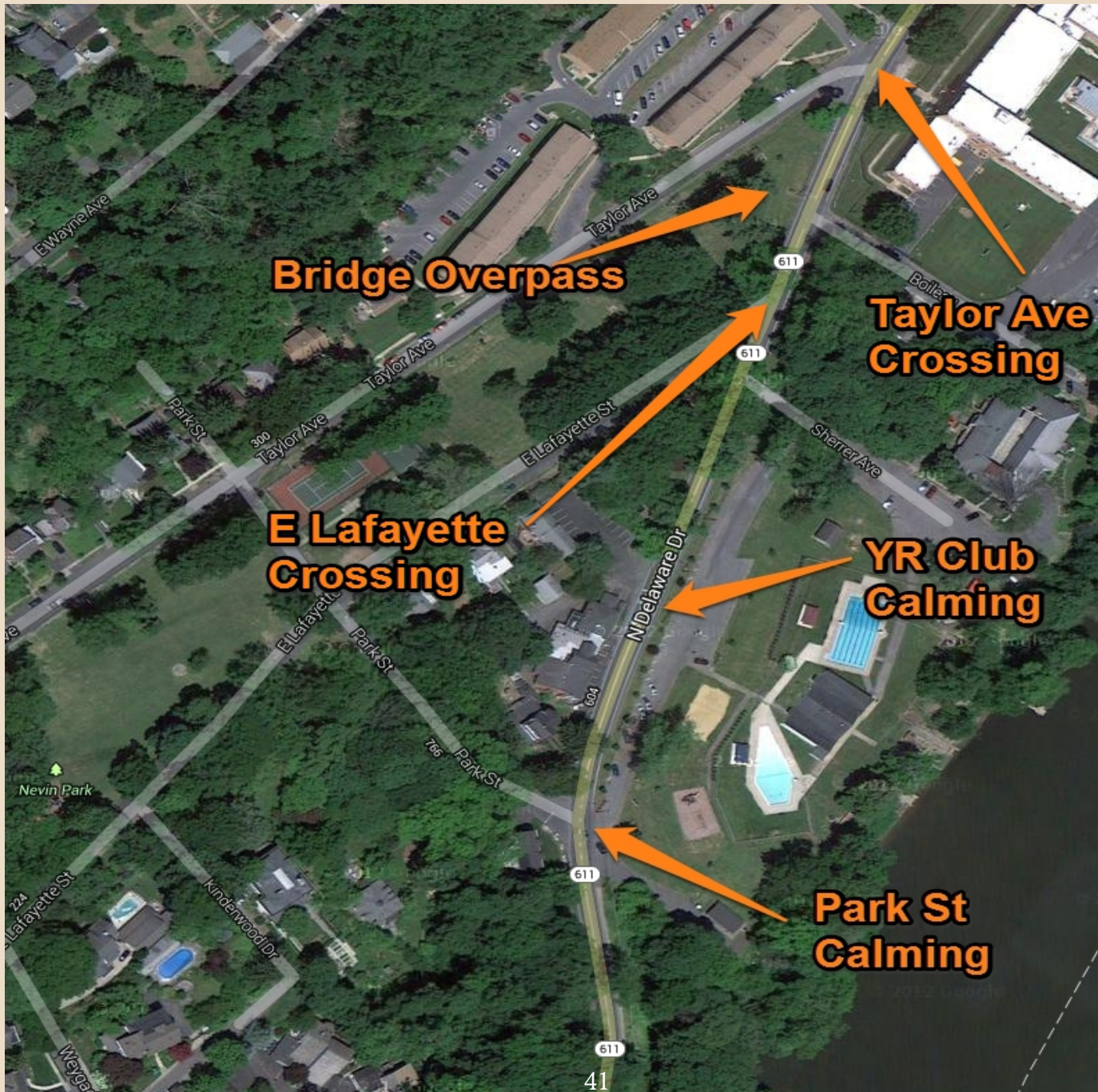

# Current Crossing Between Nevin and Eddyside



# Young Republicans Club Crossing

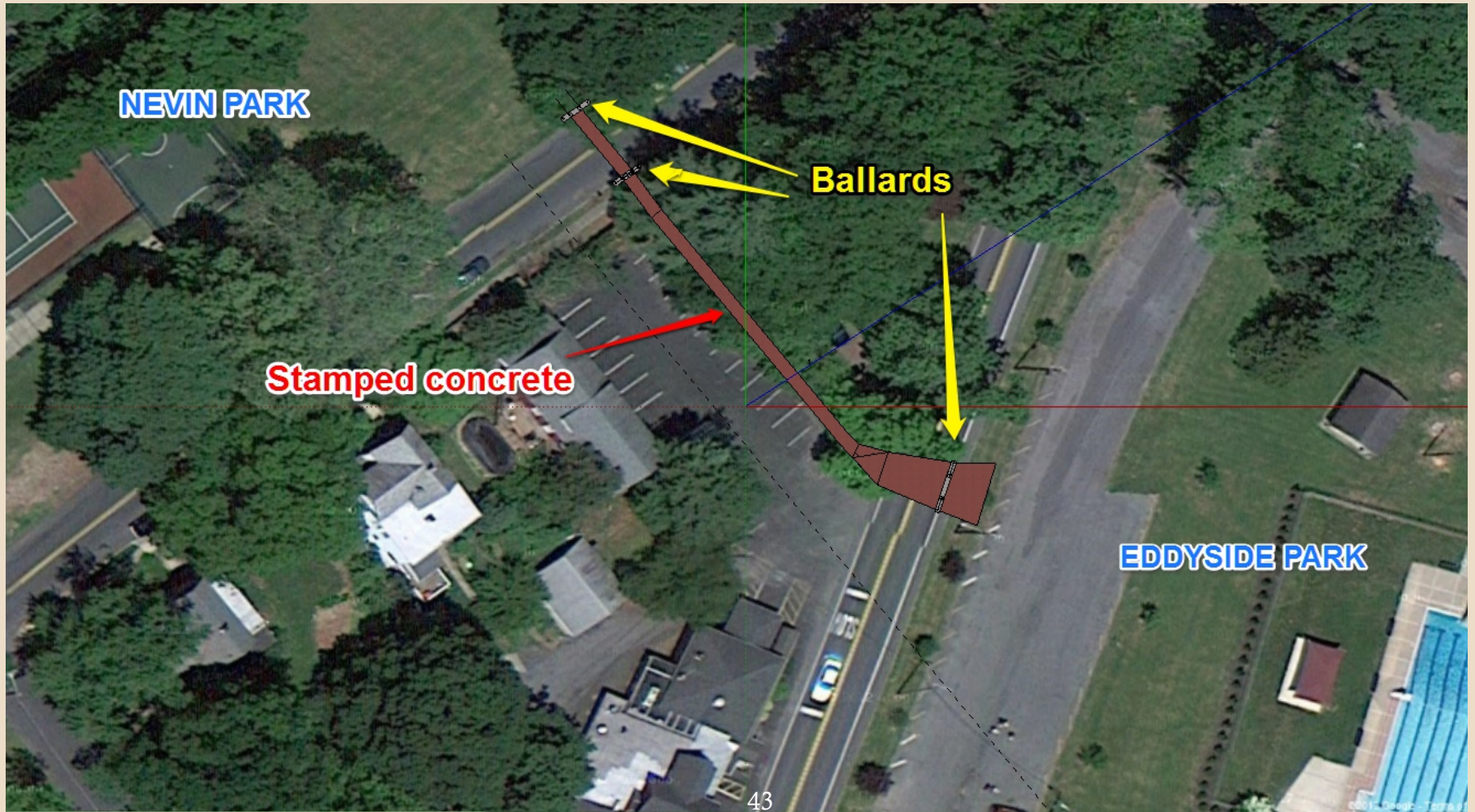

# Park Street/611 Crossing



# Pedestrian Bridge Crossing

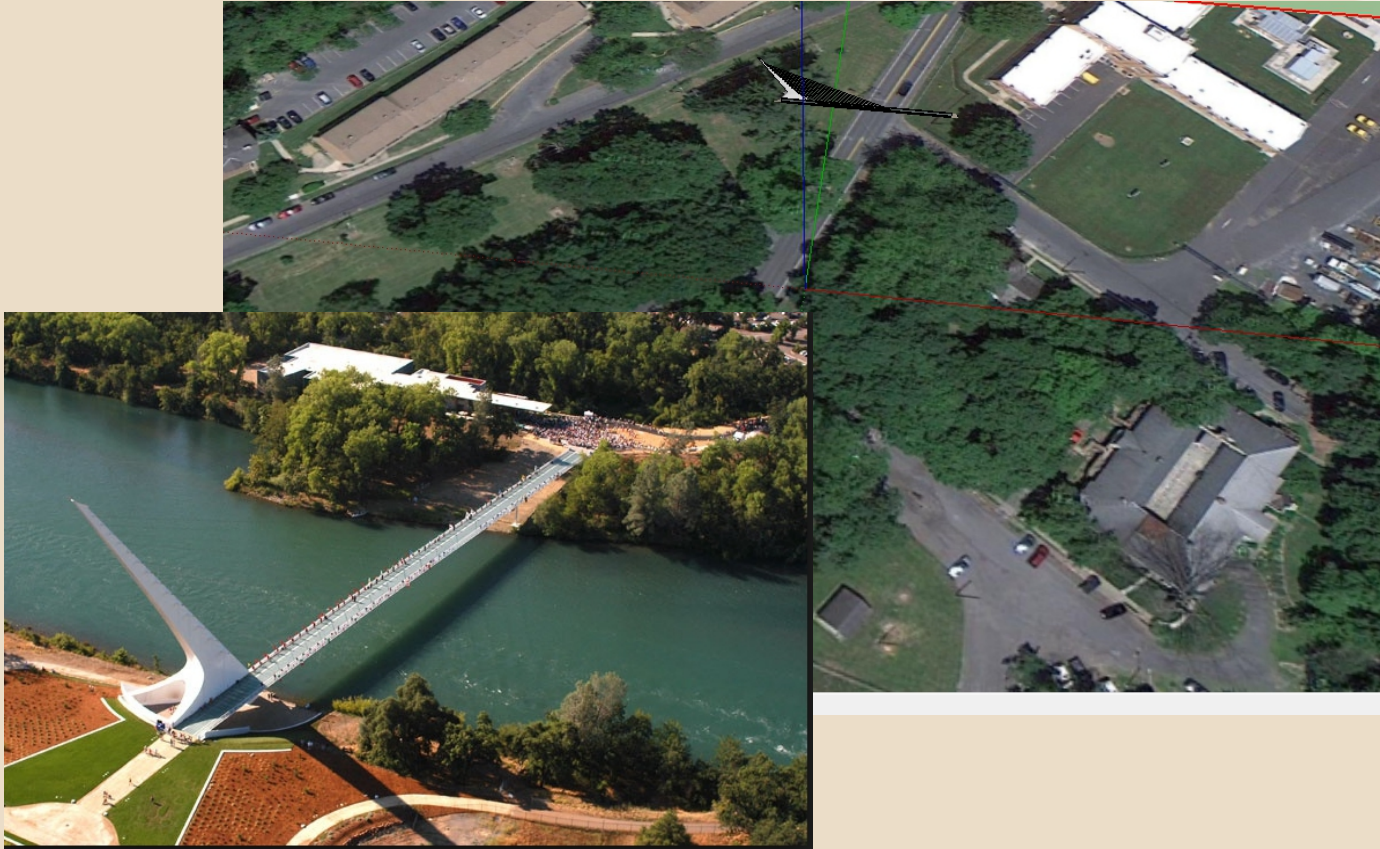

A pedestrian bridge crossing route 611 makes an attraction, such as this Calatrava bridge over a river in Redding, California but was rejected as prohibitively costly.

# Parking



- Little parking *is seen to exist* around the perimeter of Nevin Park.
- To make park patrons more aware of parking:
  - Draw lines at corner to signal parking along edges on Taylor Avenue.
  - Put up signs to specifically allow parking and to direct people to parking at Eddyside
  - Utilize planters to mark parking spaces
    - Adds color and elegance
    - Movable for when needed (snow plowing, etc.)

# Handicapped Access



- Slope makes park less accessible for handicapped individuals
- Solutions:
  - Pavilion or gazebo: flat, covered area for rest or to enjoy the park
  - Graded pathways: allows those with physical limitations to better navigate the park

# Event Communication



- Currently: events advertised by e-mail or by sign (near the WaWa on Cattell Street)
- It seems likely that many of these notifications go unseen
- Current Considerations
  - Not all have e-mail or use regularly
  - E-mails get lost or forgotten easily
  - Current sign:
    - Not modern looking
    - Must be manually updated



# Sign at WaWa



- One suggestion: replace the WaWa sign with an electronic sign
  - Looks more modern
  - Easier to keep updated
  - More noticeable
  - Cost is about \$1,000



# Sign in Nevin Park



- Currently no clear entrance sign
- Addition of sign helps communication:
  - Can post event notices on rear
  - Information in central location



# QR Codes



- Short for “Quick Response Code”
  - Holds small amounts of information
  - Essentially, a 2D barcode
- Allows for instant transfer of information
  - Immediately register for events
  - Notify residents of important dates and times
- Can be used to describe park features

# Wifi



- Benefits of Park Wifi
  - Gives wider usage of QR Codes
  - Allows for more park activities
  - Visitors can check e-mail, surf the ‘web, do work, etc.
- Current Considerations
  - Supported by Mayor Panto
  - Select good location
    - Electricity access
    - Cable access
    - Protection from weather and animals

# Place Changes in Nevin: Dog Park



- Added in section below Park Street (portion of land not fully utilized)
- Will not disrupt main area of Nevin Park
- A leash-free area in close proximity to residents
  - Currently no option for leash-free dog activity on College Hill

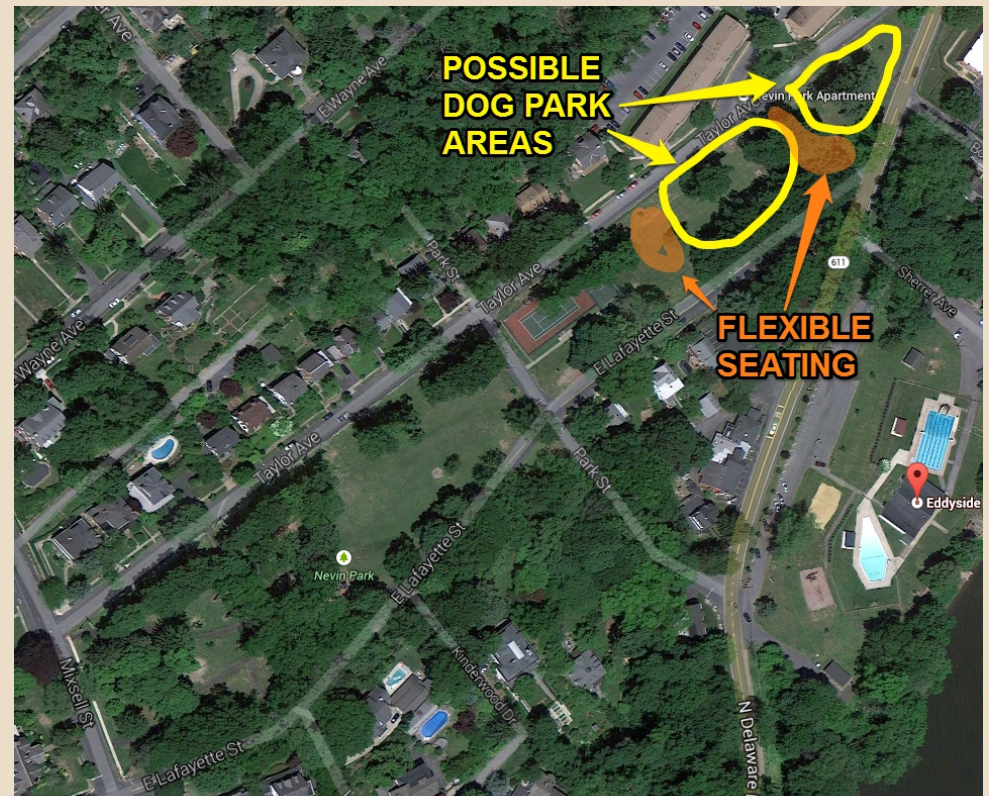

# Place Changes in Nevin: Gazebo

- Encourages interaction among neighbors
- Suggests planning events to fill it
- Provides a place of shelter from sun and rain
- Note: should be located to complement fountain and not impede sledding

# Place Changes in Nevin: Amphitheater

- Use the park's natural slope to create an amphitheater
- Encourages community socialization
- Creates a place for programming events
- Can utilize grid pavers
- Possible locations include below the tennis courts or just above Park St., on the side towards Taylor Ave.



# Place Changes in Nevin: Grid Pavers

- The open concrete grid allows greenery to grow and water to soak into the soil
- Provide excellent drainage and protection from erosion
- Walking path
- Suggest podium for the amphitheater
- Protect slopes vulnerable to erosion and damage from vehicles (i.e. car shows, maintenance)



<http://www.gardenista.com/posts/eco-friendly-paving-solutions>



# Place Changes in Nevin: Restroom Options

Restrooms are a common feature that many have expressed a desire for at Nevin Park. Price ranges for restrooms range from approximately \$700 to upwards of \$30,000.



# Place Changes in Nevin: Better Seating



## Social Place:

- Comfort comes from the ability to customize
- Movable chairs
- Adirondack chairs have been successful at Lafayette



# Place Changes Eddyside: The Boardwalk



The addition of a boardwalk would transform Eddyside into a destination. It would serve not only as a physical connector between Riverside Park, Eddyside Park, and Nevin Park, but it would also provide a vista to the Delaware River.



# Inspiration: James River Boardwalk



# Place Changes Eddyside: Riverside-Eddyside-Nevin Path



- A long-term goal for the project would be to expand the Boardwalk into a path connecting Riverside, Eddyside, and Nevin Parks.
- Grant money may be available for creating connections between parks, as well as for the beautification of park paths.

# Place Changes Eddyside: Mural

- “Create a mural which not only brings color to Eddyside Park, but also creates a sense of community pride and involvement.”
- Would be located on the side of the pool house at Eddyside.
- Would provide color, inspiration for movement, and pride for the city and Eddyside park.
- Local artists provide design ideas, city residents chose the winning design, and all could be involved in the construction of the mural.
- Theme suggestions:
  - Kids engaging in outdoor activities (swimming, biking, playing- inspired by the “Let’s Move” campaign)
  - A vista view of the river at Eddyside
- Project would be inexpensive and short-term project with big benefits for the aesthetic appeal of the park.

# Inspiration for the Mural at Eddyside



Example Mural

Let's Move Campaign



# Place Changes Eddyside: Quoits

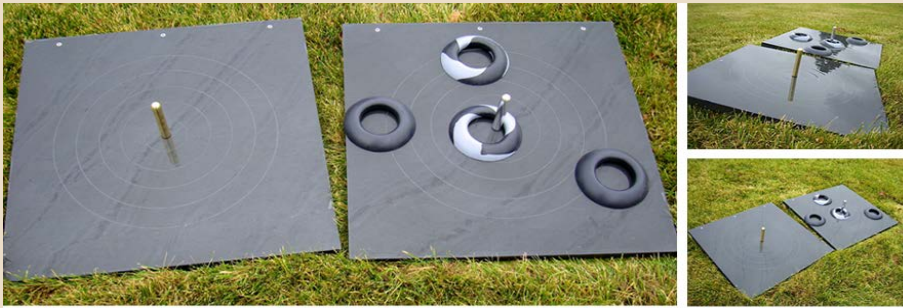

\$250 for a complete set of slate boards, hubs, screws, and rubber quoits

Can be purchased from a local factory in Belfast, PA





# Making Choices

Creating places depends on making good choices involving values held by members of the community, as well as among the resources available - human and financial. We are suggesting a tool for such choices. We can provide a workshop on the use of Wisedecider software.

# Wise Decider Software



- Online program that facilitates the making of decisions.
- We use this software to enable a logical and thorough approach to making decisions.
- Reflect a variety of values and points of view in our approach.

# “Alternatives”

The first step in the Wise Decider program is to name the alternatives that are part of the decision.

The screenshot displays the 'Alternatives' step of the Wise Decider program. At the top, there is a navigation bar with tabs for 'Getting Started', 'Alternatives', 'Values', 'Outcomes', 'Deciding', and 'Wrapping Up'. The 'Alternatives' tab is currently selected. Below the navigation bar, there is a list of six alternatives. Each alternative has an input field for the alternative name, an input field for notes, and a 'Delete' button. The alternatives listed are: 'Park Street/611', 'YR Club', 'Nothing', 'East Lafayette', 'Taylor Avenue', and an empty field. At the bottom of the list, there is a blue button labeled 'Add another item' and a larger blue button labeled 'Save'.

Alternative	Notes	Action
Park Street/611		Delete
YR Club		Delete
Nothing		Delete
East Lafayette		Delete
Taylor Avenue		Delete
		Delete

[Add another item](#)

[Save](#)

# “Values”

The next step is the assignment of values that influence the decision you are attempting to make between the various alternatives.

**Crossing Points**

Getting Started Alternatives **Values** Outcomes Deciding Wrapping Up

<b>Value</b> Ease of Use	<b>Notes</b>	Delete
<b>Value</b> Overall Inclination	<b>Notes</b>	Delete
<b>Value</b> Accessibility	<b>Notes</b>	Delete
<b>Value</b> Safety	<b>Notes</b>	Delete
<b>Value</b> Political Aspects	<b>Notes</b>	Delete
<b>Value</b> "Attraction"	<b>Notes</b>	Delete
<b>Value</b> Financial Cost	<b>Notes</b>	Delete
<b>Value</b>	<b>Notes</b>	Delete

Add another item

# “Outcomes”



- In this section, you rate the values that you previously selected in regards to their favorability.
- The lighter the shade, the more favorable, and vice versa.

**Description**
✕

**Unfavorable****Favorable**

Clear Rating

Done
Cancel

## Crossing Points

- Getting Started
- Alternatives
- Values
- Outcomes
- Deciding
- Wrapping Up

	Ease of Use	Overall Inclination	Accessibility	Safety	Political Aspects	"Attraction"	Financial Cost
YR Club							
Park Street/611							
Nothing							
East Lafayette							
Taylor Avenue							

# “Deciding”



In this final section, you can move different values around in order to compare them, and gain a clearer picture of which values trump others, and ultimately decide on which alternative is the more favorable one.

# Crossing Points

Getting Started

Alternatives

Values

Outcomes

Deciding

Wrapping Up

	Ease of Use	Overall Inclination	Accessibility	Safety	Political Aspects	"Attraction"	Financial Cost
YR Club							
Park Street/611							
Nothing							
East Lafayette							
Taylor Avenue							



# Conclusions regarding Wise Decider



- This Wise Decider program is very useful for making difficult decisions.
- It exemplifies the Technology Clinic's method for arriving at decisions.
- We aim to reflect a variety of values and points of view held by the CHNA as well as community members.

# Conclusion

We hope that we have provided a number of useful ideas for the City of Easton, the College Hill Neighborhood Association and indeed for all members of the College Hill neighborhood to consider in transforming Nevin and Eddyside Parks from good places to great places. This place-making process is an on-going one, each generation improving public locales for the next.

*The Tech Clinic Team*

# Acknowledgements



Hubert Etchison

Jerry Nissen

Phyllis Johnson

Prof. Lawrence Malinconico

Prof. Susan Niles

Judy Bauer

Dave Hopkins

Claire Degnan

Kay Wolff

Erik Daly

David and Mary Liz Colley

And many others

# Appendices:

1. Accessible Pathways
2. Riverside Boardwalk
3. Mural Construction
4. Toilet Possibilities
5. Seating Possibilities
6. Dog Park Considerations
7. Gazebo
8. Crossing Between Nevin and Eddyside



# ADA Guidelines for Accessible Pathways



- Accessible routes shall consist of one or more of the following components: walking surfaces with a running slope not steeper than 1:20, doorways, ramps, curb ramps excluding the flared sides, elevators, and platform lifts.
- The running slope of walking surfaces shall not be steeper than 1:20. The cross slope of walking surfaces shall not be steeper than 1:48.
- The clear width of walking surfaces shall be 36 inches (915 mm) minimum.

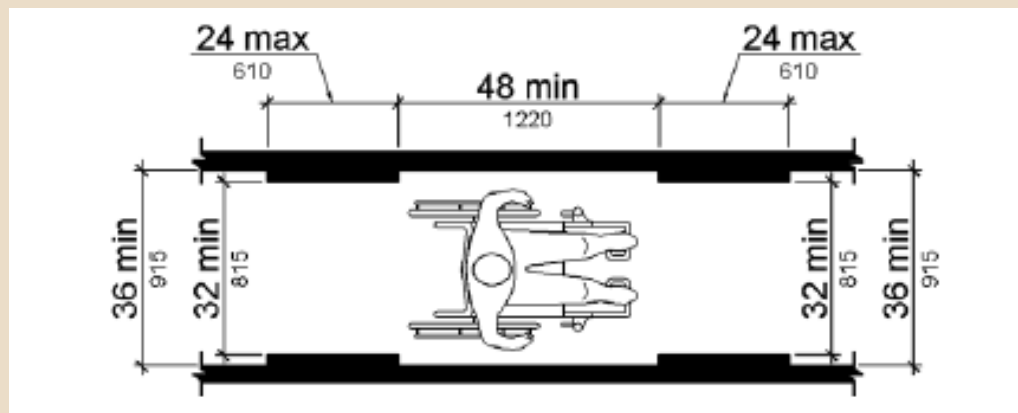

[www.ada.gov/](http://www.ada.gov/)

# Accessible Pathways



- Where the accessible route makes a 180 degree turn around an element which is less than 48 inches (1220 mm) wide, clear width shall be 42 inches (1065 mm) minimum approaching the turn, 48 inches (1220 mm) minimum at the turn and 42 inches (1065 mm) minimum leaving the turn.

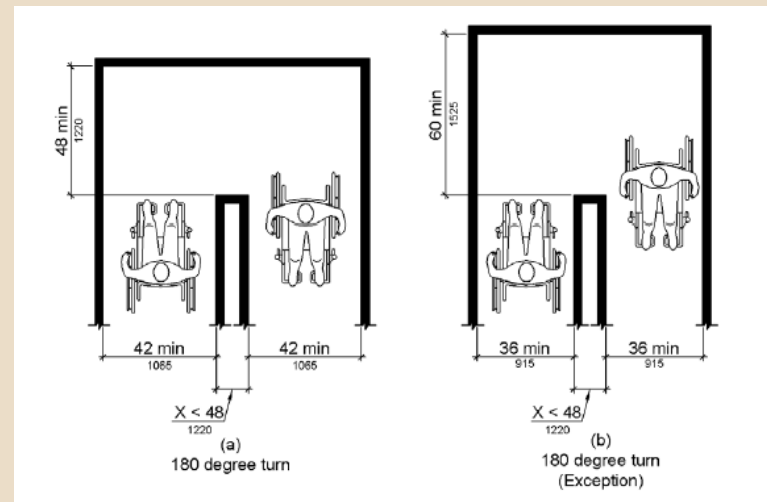

[www.ada.gov/](http://www.ada.gov/)

# Accessible Pathways



- An accessible route with a clear width less than 60 inches (1525 mm) shall provide passing spaces at intervals of 200 feet (61 m) maximum. Passing spaces shall be either: a space 60 inches (1525 mm) minimum by 60 inches (1525 mm) minimum; or, an intersection of two walking surfaces providing a T-shaped space complying with 304.3.2 where the base and arms of the T-shaped space extend 48 inches (1220 mm) minimum beyond the intersection.
- Source: [www.ada.gov/](http://www.ada.gov/)

# Rest Stop Guidelines

## (from US Department of Transportation)



- Rest areas are most effective when placed at intermediate points, scenic lookouts, or near trail amenities. Rest areas located off the trail allow stopped trail users to move out of the way of continuing traffic. The most inviting rest areas have a bench, shade, a place to rest bicycles, and a trash receptacle. Water fountains and washroom facilities are also useful on long trails.
- Source: [www.fhwa.dot.gov/](http://www.fhwa.dot.gov/)

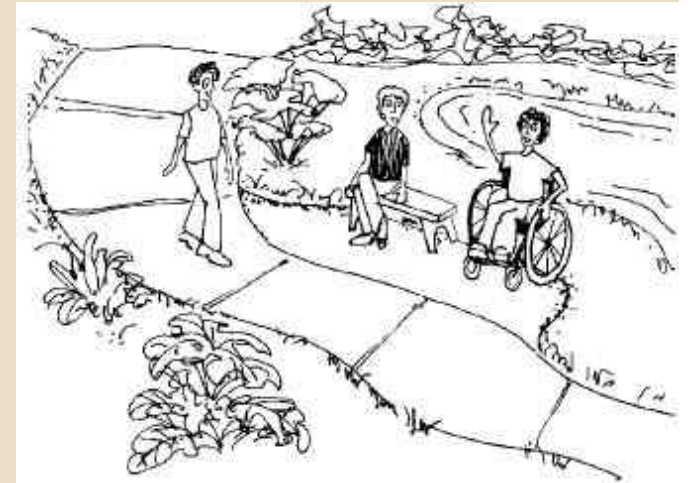



# Rest Stop Guidelines

## (from US Department of Transportation)



- Easier, moderate, and difficult trails should have rest areas at maximum intervals of 121.9 m, 274.3 m, and 365.8 m (400 ft, 900 ft, and 1200 ft), respectively. The California State Parks Guidelines call for rest areas on easier, moderate, and difficult ORARs at maximum intervals of 61.0 m, 121.9 m, and 182.9 m (200 ft, 400 ft, and 600 ft), respectively. The New Mexico Plan specifies 402.5 m (1,321 ft) as the maximum allowable interval between rest areas on difficult trails.
- Source: [www.fhwa.dot.gov/](http://www.fhwa.dot.gov/)

# The Boardwalk



- “Create a boardwalk at Eddyside Park which can serve as a vista to the river.”
- Phase One: construction of the Boardwalk overlooking the river at Eddyside Park. Boardwalk will not be connected to Nevin or Riverside Parks, but will be a scenic overlook to the river. The Boardwalk will attract people to Eddyside’s natural water feature and provide a window to the river.
- Phase Two: extend the Boardwalk to connect to trails running through Riverside Park and Nevin Park. Will lead to increased patronage in all three locations, serve as a biking, walking, and running path, and also allow for more opportunities for grant money.
- Will provide an important link between Riverside Park, Eddyside Park, and Nevin Park once completed.
- Would be an expensive and long-term project, but would be long-lasting and would create a destination at Eddyside.

# Schuylkill River Boardwalk



- Boardwalk Design: URS Corporation
  - 715 Washington Boulevard, Williamsport PA 17701
  - (570)-505-1674
- Ramp Design: Michael Baker Jr Inc
  - 300 American Metro Blvd, Hamilton Township NJ 08619
  - (609)-734-7900
- Construction: Crossing Construction Company Inc.
  - 1087 Taylorsville Rd, Washington Crossing PA 18977
  - (215)-493-0205
- Received grants from: the Commonwealth of Pennsylvania, Federal Highway Administration, and the Transportation Improvements Generating Economic Recovery (TIGER) program

# Mural Construction



1. Remove all old paint
2. Wall must be washed with soap and water
3. Mold and mildew removed with 1 part bleach 3 parts water solution
4. Cracks and grooves in the wall should be filled
5. Primer coat with Masonry Conditioner should be applied to the entire wall.
6. Acrylic paint should be used to construct the mural

Golden Product (not modified)	Smooth Textured Surface	Moderately Textured Surface	Heavily Textured Surface
Heavy Body Acrylics	✓⊙		
Matte Acrylics	✓		
High Load Acrylics	✓	✓	
Fluid Acrylics	✓	✓⊙	✓⊙
Airbrush Acrylics	✓	✓	✓

✓ Can be used for this surface    ⊙ Best Recommendation for particular surface

# Possible Restroom Contractors

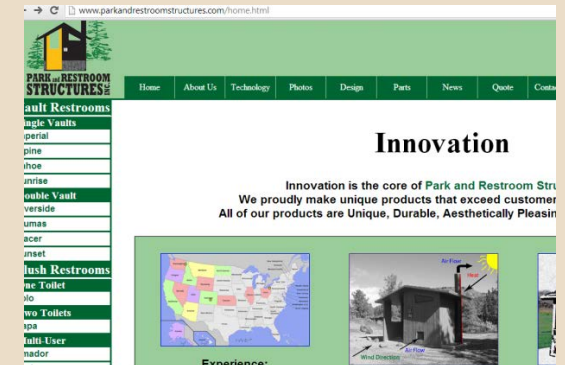
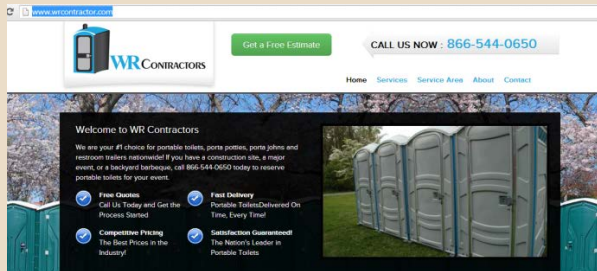

To rent portable toilets for big events:  
<http://www.wrcontractor.com/>

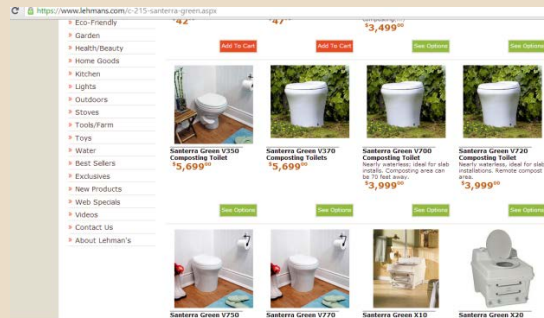

# FAQ: Composting Toilets



## • **WHAT ARE COMPOSTING TOILETS?**

- Toilets which use little or no water and treat toilet wastes on-site for reuse as valuable compost.

## • **HOW DO THEY WORK?**

- They work by providing a enclosed environment for the natural process of aerobic decomposition. The same type of environment on forest floors which decomposes wildlife droppings and converts them into valuable nutrients for the vegetation to use.
- There are many different designs of composting toilets, but all carry out this basic process of aerobic decomposition. Design variations enhance this process

and they include:

- air baffles for distribution of air into the pile
- heating units to keep the compost at the best temperature
- injected air for increased decomposition
- mixing tongs to ensure full decomposition throughout the pile
- the addition of composting worms and macro-organisms

## • **WHAT ARE THE ADVANTAGES TO THE USER AND OWNER?**

- Greatly reduced water storage or supply costs, possibility of a rebate for community sewage charges, production of compost, in many systems the ability to compost vegetable peelings and garden trimmings with toilet wastes.

## • **WHAT ARE THE ADVANTAGES TO THE COMMUNITY?**

- If a community were to embrace the total use of composting toilets and appropriate greywater systems, it would have no sewage charges, sewage pipe installations and maintenance costs.
- The community would also have greatly reduced water costs.
- It could also reduce its rubbish collection charges through recycling most vegetable matter, and would be able to produce valuable compost and worm castings for sale or reuse in community and private gardens.

# Adirondack Chairs



www.dutchcrafters.com/Amish-Made-Polywood-Comfo-Back-Adirondack-Chair/p/6389

**dutchcrafters**  
Amish Handcrafted in America

866-272-6773

Search by Tag: Quick Ship, Gifts for Her, Gifts for Him

Blog New Arrivals Furniture By Styles Furniture By Collections Testimonials About Us Made in America Learning Center Trade

Kitchen & Dining Living & Entertaining Bedroom Office Outdoor Children Decor Foyer Bath Pets Furniture Care Sale

ONLY **30%** DEPOSIT ON FURNITURE ORDERS | COLOR MATCHING? **STAIN** SAMPLES AVAILABLE

[Outdoor / Amish Outdoor Chairs](#)



**Amish Made Poly Wood Comfo-Back Adirondack Chair**  
(Product ID:6389)

**QUESTIONS?** Call 866-272-6773 or get answers by Email

**PRICE MATCHING OFFERED**  
on this product \*Restrictions Applied

**FREE GROUND SHIPPING**

Select 15"X15" Throw Pillow

Select Back Cushion

www.patioandcompany.com/a-l-furniture-co-kennebunkport-adirondack-chair.html

Outdoor Patio Furniture My Account | Check Order Status | Contact Us | My Wishlist | Login  0 Items \$0.00

**Patio & Company**  
A WestChaseShops Store

Search entire store here...  (800) 284-8583  
Mon-Fri 9-5 EST

Porch Swings Outdoor Gliders Outdoor Benches Bistro Sets Chaise Lounges Rocking Chairs Adirondacks Patio Sets Umbrellas Cushions

**Free Shipping On All Orders** Limited time offer 48 continental US only

Home / A&L Furniture Co. Kennebunkport Adirondack Chair



**A&L Furniture Co. Kennebunkport Adirondack Chair**  
Product SKU: ALF-008

2 Reviews

**Made To Order**

- Ships FREE in 3-5 Bus. days [Shipping Details](#)
- High-quality, knot-free yellow pine for long-lasting durability
- Adds class to any outdoor seating area
- Amish craftsmen pay great attention to each detail
- Woodworkers select each piece of wood for its grain and other individual characteristics [View all product details](#)

Notify me about updates [Sign Up](#)  
Not ready to buy yet? [Add to Wishlist](#)

Select Color

Source: PPS

# Benches and PPS Recommendations

## IS A BENCH NEEDED?

The most important decision that needs to be made in selecting a bench, or any other type of public space amenity, is whether it is needed and whether it will be used. This requires visiting the area and noting the types of seating that already exist; the types of land uses (e.g., shops, offices, residences) that are along the street; and the potential clientele (e.g., office workers, shoppers) in the area who would be likely to use the benches. Locations where people already sit (on steps, ledges, etc.) should also be noted. This type of on-site observation is important in making decisions about where, how many, and what types of benches are needed.

## BENCH DESIGN GUIDELINES

### **The Seat**

To be comfortable, there should be a 95-105 degree angle between the seat and the back, and the seat should be between 2 and 10 degrees off of horizontal.

The depth of the seat should be 12 to 18 inches for benches with backs and 30 inches for backless benches.

A seat height of 18 inches is generally the most comfortable.

The front edge of the seat should be curved rather than squared off.

The most comfortable seating surface is wood, which is resilient and does not readily conduct heat or cold.

Small bench slats (2 inches) spaced closely together and following a contoured form are generally more comfortable than larger slats (8 inches). However, in areas where vandalism is a factor a larger size (e.g., 3 inches x 8 inches) should be used.

The length of the seat should allow for twenty-four inches per person. However, people will sit closer to each other if there is an armrest separating them.

### **The Back**

Seatbacks that slope back slightly and have a slight curve are the most comfortable.

The height of the backrest should be 20 inches to provide support for people's backs and shoulders.

Benches with no backs allow people to sit on both sides at the same time.

### **The Legs**

The legs should not extend out past the seat, otherwise people may trip on them. If a large, solid leg is used, a kickspace (3 inches minimum) under the seat is needed.

### **Armrests**

Armrests are useful both to help people to get out of the seat, and to divide a bench so that more people can fit along it. Segmenting the bench into sections through the use of armrests can provide a sense of privacy among groups as well as encourage people to sit closer together. The edge of the armrest should extend out to the edge of the seat, and it should have a firm, rounded gripping surface.



# Benches and PPS Recommendations

- LOCATION AND PLACEMENT

- Locations for benches are places where there are people – places where people wait for rides, taxis or buses; outside department stores and office building entrances; near food shops; and anywhere that people can watch other people. Bad locations are places where there is little activity, such in front of banks that close early, buildings without windows, places that are hidden from view or located too far from activity. Once a decision has been made about the general location, the following guidelines can be used in positioning benches along a street
- *Benches should be placed within view of the action, but out of the way of the flow of pedestrian traffic.* They should be set back at least 24 inches from the pedestrian walkway to allow space for people walking by. (However, a bench should not be set back too far, or it will not be used.)
- *Benches should be placed together with other street amenities such as bus shelters, kiosks, newsstands, waste receptacles, telephones, etc.*
- *Benches should not face each other directly unless they are being used for games.* People tend to feel uncomfortable when they sit face to face with a stranger, and will twist around or sit sideways to avoid eye contact. Occasionally, pairs of benches should be placed at a 90 to 120 degree angle, which is good both for conversations and for sitting alone.
- *Benches should generally not be lined up in a row because this makes it difficult for a group to have a conversation.* (Where there are many passersby or where there is an outstanding view, benches can be lined up.)
- *Benches should be located so as to give people a choice to sit in the sun or shade, and where there is protection from strong winds.* The widest range of choice is provided by using movable chairs or lightweight benches.
- In areas where disabled people are likely to sit, *benches should be spaced so that wheelchairs can be accommodated on the side or in front of the bench.* This will allow people in the wheelchairs to talk with people on the bench, without being in the way of passersby. People who use walkers also need space to rest their walker adjacent to the bench while they are seated.

# Benches and PPS Recommendations

## DESIGN

- Comfort is an important factor in designing a bench. But how comfortable a bench needs to be depends on how it will be used. For example, on a shopping street where people will stop briefly with packages, comfort is not as important as in a park where people may spend an entire afternoon. Concern for comfort must be combined with other considerations. For example, in an area where teenagers may sit on the backs of the benches, a bench with large slats, which is stronger, should be used, even though for sitting large slats are less comfortable than smaller ones. The general lesson to be kept in mind is that all factors must be considered together in choosing or designing a bench for a particular location.
- A second factor in bench design is appearance. It is important that a bench fits in with its surroundings. The reason for this is that a bench, which appears to be an extension of the property it sits next to, will help to give a proprietary feel to the street. This increases the likelihood that business owners will take care of the bench (and the street) that will, in turn, have a positive effect on safety and security in the area.
- The following design guidelines can be used in designing or selecting a bench that is suitable for most situations:

# Benches and PPS Recommendations

## MAINTENANCE & MANAGEMENT

Benches should be constructed of durable materials that are resistant to weather, vandalism, and rusting. Benches can be made of concrete, wood, iron, steel, and fiberglass, but the most comfortable and durable material is wood.

If wood is used, the parts that most often require replacing are the slats. Slats should be stockpiled, or a bench manufacturer should be selected that has slats that can be reordered quickly.

Painting slats and supports requires time and funds. Some ways around painting are: using aluminum for supports; galvanizing steel supports before painting; staining instead of painting slats; and using concrete (such as in concrete standard or wall hung benches) to avoid corrosion or rust.

Using slats that are the same size aids in replacement and labor costs. Bench seating, for example, can be more economical by using as few as two different slats in one bench. Slat replacement can be made easier by the way it is attached to the bench structure and tradeoffs may need to be considered between ease of replacement and frequency of replacement. For example, a rod through a contour bench requires more time to be replaced than using bolts directly to the bench structure. However, the rod attachment is stronger and so it does not have to be replaced as often as using bolts.

Installation should be inexpensive, time efficient, and durable as possible. Installation plans should allow for experimentation with location, and bench arrangement.

Because many cities are not adequately staffed for a good bench maintenance program, benches are sometimes left derelict and broken benches are left in disrepair. This problem is magnified when people see the neglect and then make generalizations that influence their perceptions or feelings about the entire downtown.

Sometimes benches are vandalized. There is no bench that is vandal resistant. However, being aware of the likelihood of vandalism in particular areas can affect the type of bench selected for that area. The best solution to vandalism lies not in the type of bench used, but in developing an understanding of what types of vandalism occur, at what times, by what types of people, and then in trying to develop a program that will prevent it from occurring. The key to preventing vandalism in a downtown is locating benches where adjacent storeowners will assume some responsibility for their use and maintenance.

# Benches: Website Source

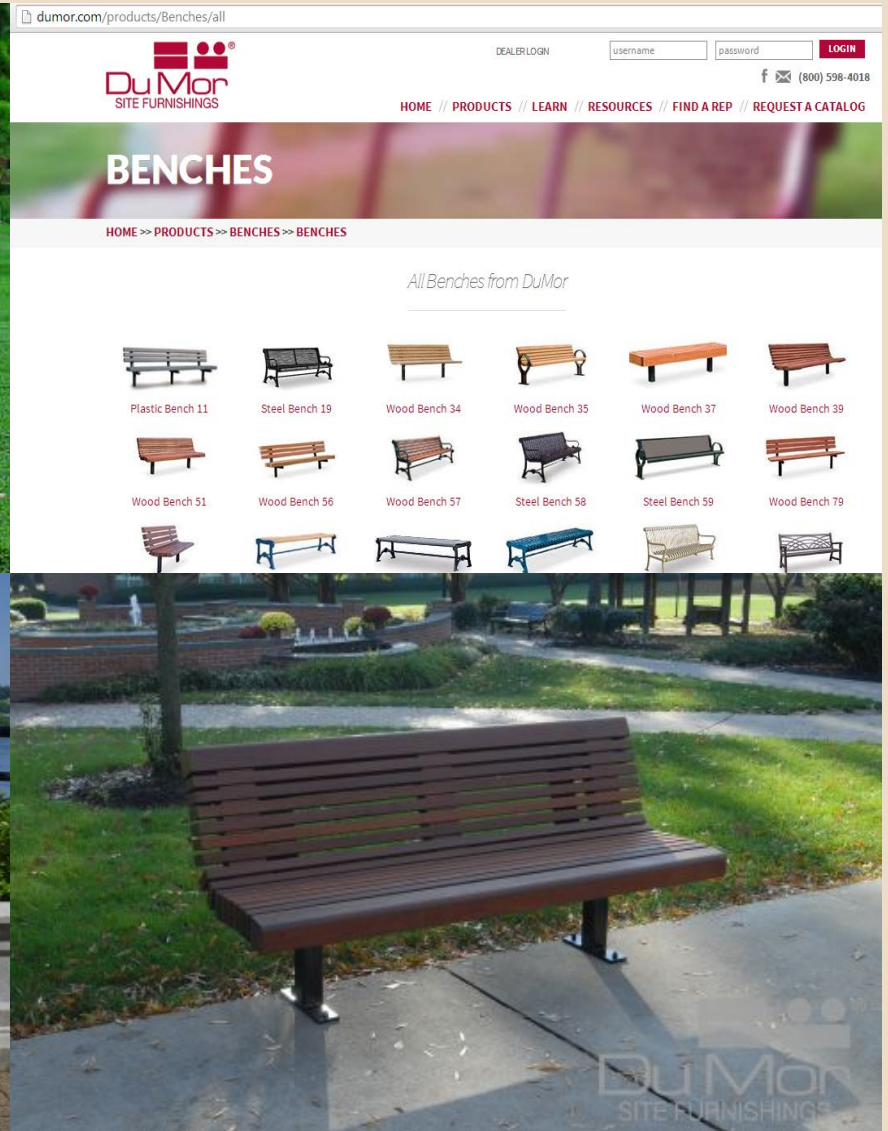

Source: PPS

# Dog Park Considerations

Location: It seems that the best location for a Dog Park would involve two considerations.

- The first would be that the space be in an unobtrusive area, such that the flow of the park is not disrupted.
- Secondly, the Dog Park should be large enough with ample terrain so that dogs can actually run around and enjoy themselves. Keeping these factors in mind, the ideal location would be in the North East Corner of the park, beyond the tennis courts. This area seems to be large enough and has enough terrain variation to be the ideal place for a Dog Park.
- Third, it should provide space where neighbors can interact while their dogs play.

# Dog Park Considerations



- Cost: For 5-6 foot tall fencing. (We would want less than that height, roughly half)
- Wood fence installation costs \$15-\$25 per linear foot.
- Vinyl fence installation costs \$25-\$35 per linear foot.
- Chain link fence installation costs \$7.50-\$15 per liner foot.

# Gazebo

Cost: \$3,000 (12 ft) - \$10,000

- Vendors: Home Depot and Lowes seem most viable, perhaps a community project?
- However, these all seem relatively small.

# Crossing Between Nevin & Eddyside

- The crossings between Nevin Park and Eddyside Park can be very useful. However, PennDot (<http://www.dot.state.pa.us>) is a vital contact if a crossing is desired between Nevin Park and Eddyside Park. This organization will have the final say in regards to the construction of traffic calming devices, pathways crossing the road, bollards, and just about every aspect of a crossing that is connected to a road.
- Safety is the primary concern in regards to the YR Club Crossing and 611/Park Street Crossing. Ideally there would be a traffic light or a stop sign next to the crossing that would slow down traffic or even stop it when people are utilizing the crossing. PennDot is unlikely to approve a stop sign or traffic light that halts traffic, but a possibility of a flashing pedestrian sign remains. This type of sign would be solar powered and thus very cost effective, and when a button is pushed the lights begin to flash to alert oncoming traffic that a pedestrian is crossing the street. Additional traffic calming devices such as bollards or brick/grooved pavement would be helpful in telling drivers that they are now in a pedestrian zone and must slow down. Again, the question of approval from PennDot is of the utmost importance, and everything involving the crossing revolves around PennDot.